

DRAWING MADE IN THIRD ANGLE PROJECTION

THIS DRAWING IS UNPUBLISHED. RELEASED FOR PUBLICATION, 19 .
 © COPYRIGHT 19 BY AMP INCORPORATED, HARRISBURG, PA. ALL INTERNATIONAL RIGHTS RESERVED. AMP PRODUCTS MAY BE COVERED BY U.S. AND FOREIGN PATENTS AND/OR PATENTS PENDING.

| LOC | DIST | P | F | ZONE | LTR | DESCRIPTION | DATE | APPROVED |
|-----|------|---|---|------|-----|--------------------------|----------|----------|
| CE | 16 | | | | J | REV PER CE-2545 | 12-17-92 | RH/GL |
| | | | | | K | REVISED PER 0A00-0049-99 | 19FEB99 | KM |

1. DIMENSIONS IN [] ARE IN INCHES

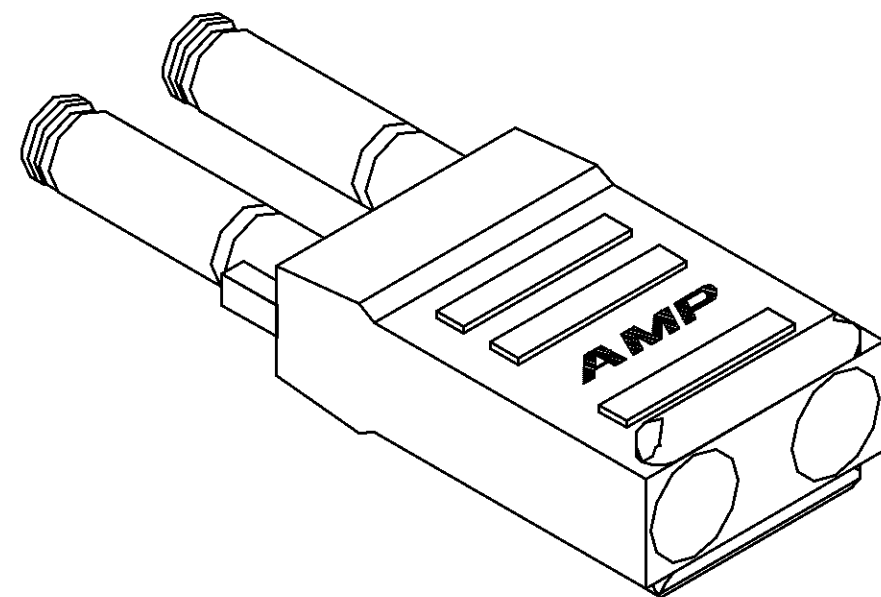
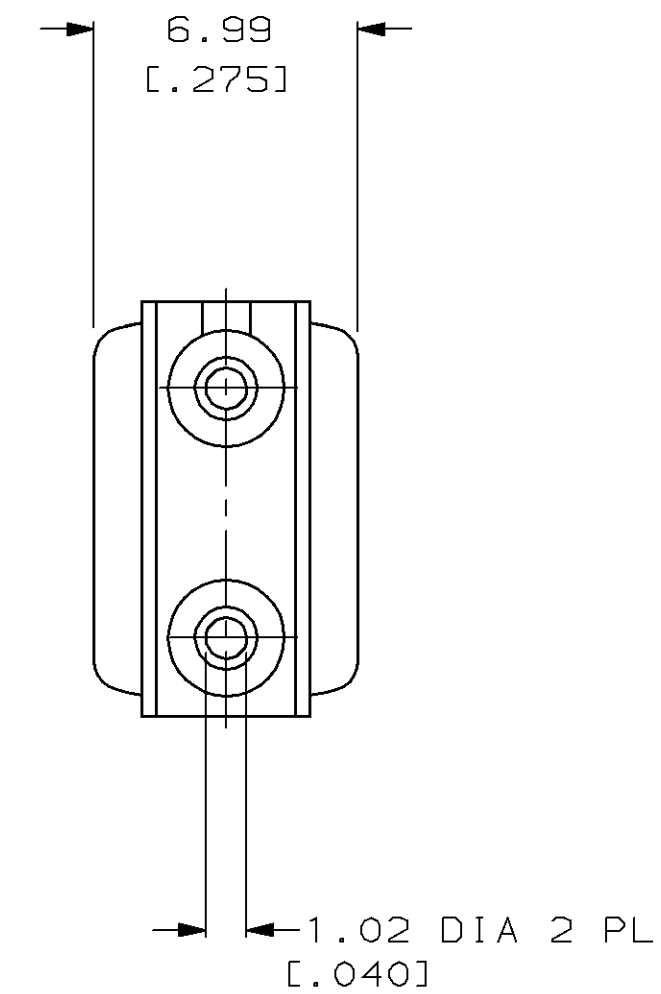
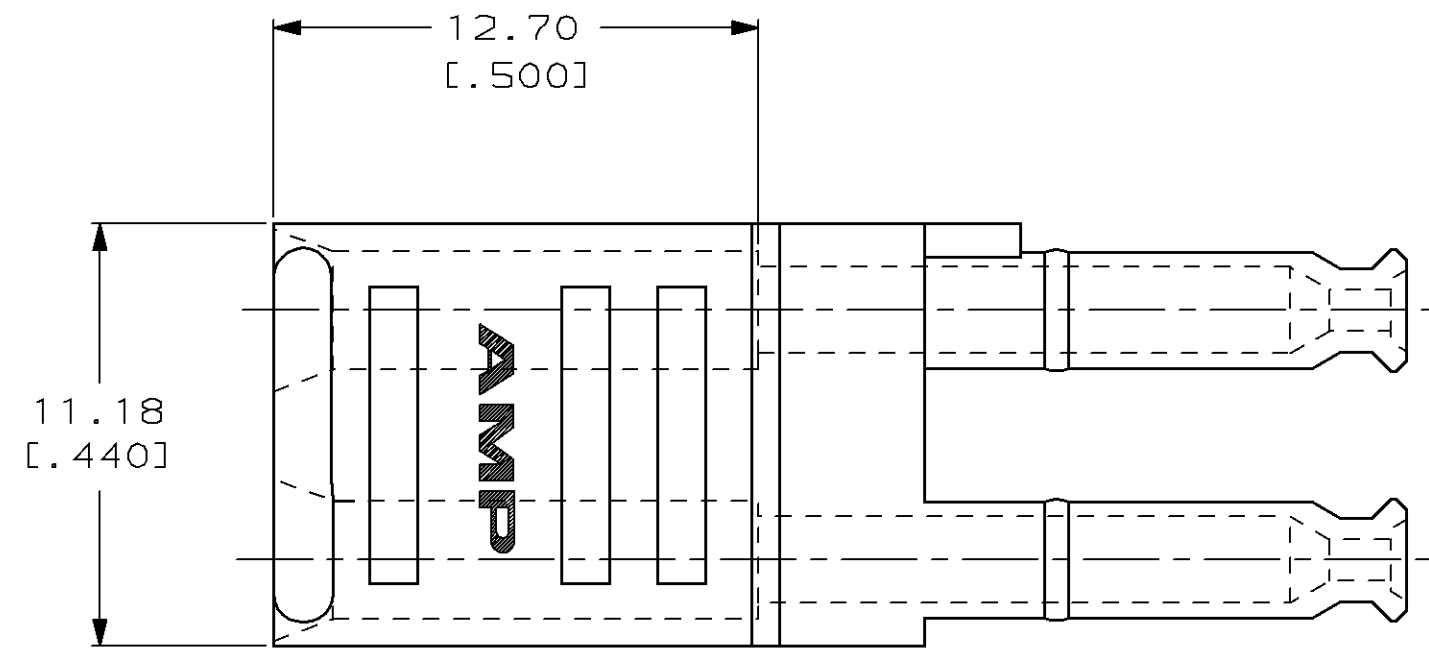
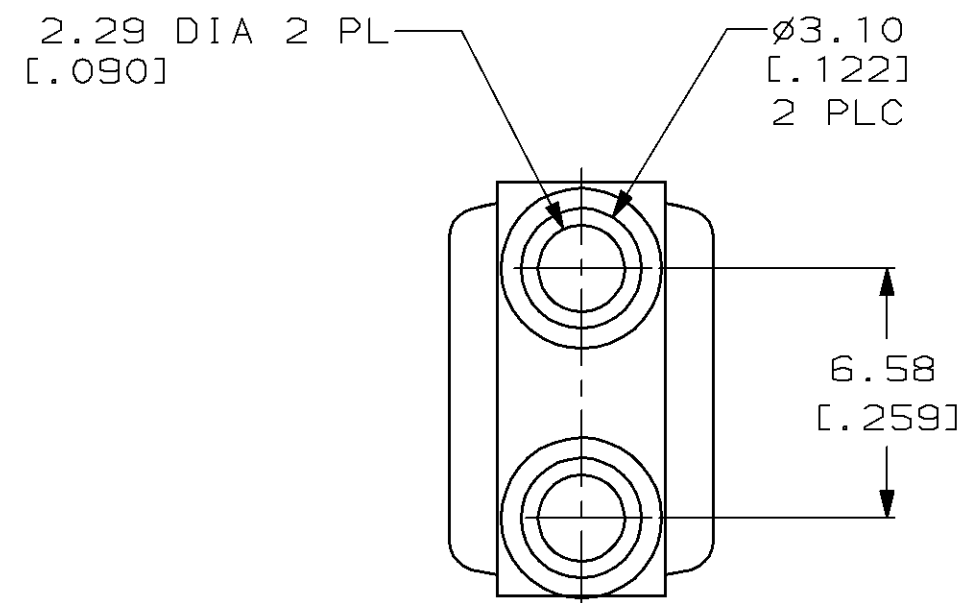
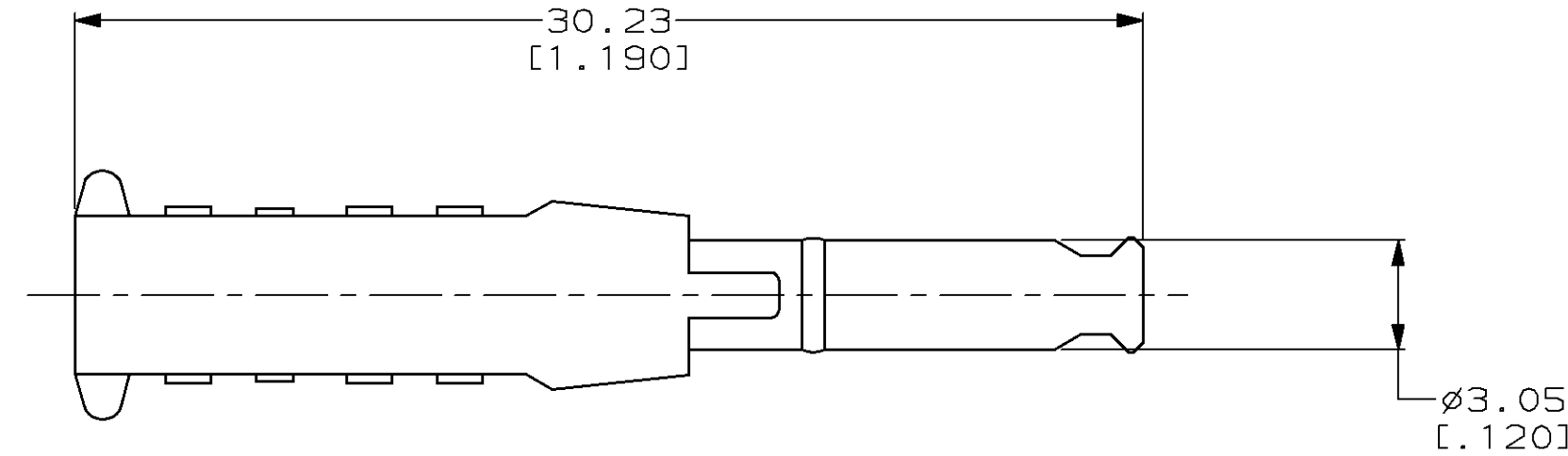

METRIC

| | | | | | |
|---|--|------------------------|--|---|--|
| UNLESS OTHERWISE SPECIFIED DIMENSIONS ARE IN MM TOLERANCES ON : | | DR 9-15-86 J. ZEIDERS | | 228044-1 PART NO | |
| 2 PL DEC ± .25 [0.010] | | CHK 9-15-86 W. MILLER | | AMP INCORPORATED Harrisburg, Pa. 17105 | |
| 3 PL DEC ± - | | APPD 9-15-86 A. PLOTTS | | | |
| ANGLES ± - | | APPD 9-15-86 K. MONROE | | NAME | |
| MATERIAL | | PRODUCT SPEC | | PLUG, DUAL POSITION, DNP, OPTIMATE | |
| THERMOPLASTIC COLOR: BLACK | | 108-45104 | | DRAWING NO | |
| FINISH | | APPLICATION SPEC | | SIZE | |
| - | | IS SHEET 2974 | | C 00779 | |
| WEIGHT | | .90g | | DRAWING NO | |
| | | | | 228044 | |
| | | | | SCALE NTS | |
| | | | | SHEET 1 OF 1 | |